

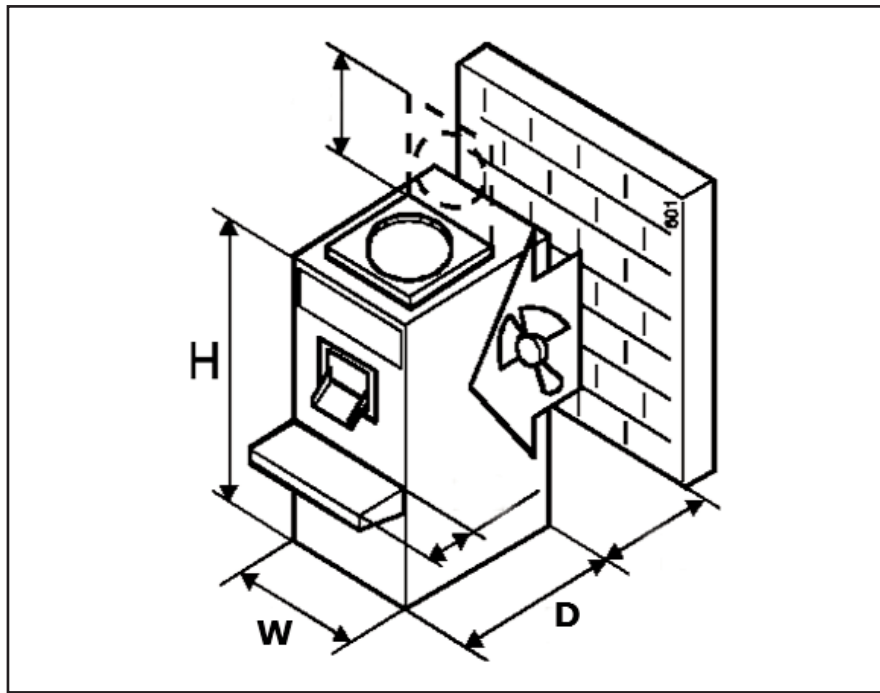

- Vertically oriented freezing cylinder provides high capacity, and maximum energy efficiency.
- Large diameter freezing cylinder facilitates extremely fast freezing times, resulting in very small ice crystal formation.
- Easy cleaning and simple assembly of beater parts.
- Low cost, long wearing, NSF approved plastic beater blades minimize frequent and costly blade replacement.
- Heavy-duty stainless steel beater shaft built to withstand years of use.
- Clear acrylic freezing cylinder cover allows monitoring of product while freezing.
- Easy access to freezing cylinder when adding variegates and particulates.
- Provides thorough mixing of variegates and particulates unachievable with horizontal barrels.
- All controls and indicators conveniently grouped in a single panel, on the front of the freezer.
- All buttons and indicators identified by easily understood symbols relative to their function.
- Time/temperature controlled freezing achieves same smooth texture and product consistency across full and partial batches, a feature not possible with consistency controlled freezers.
- Swing gate style, stainless steel extraction door design provides rapid extraction of product.
- Robust 3.5 horsepower, semi-hermetic compressor, engineered for high quality and outstanding reliability.





	VB60	
Dimensions	Machine	with crate
width	19-1/2" (49,5 cm)	22" (55,9 cm)
height	43-1/4" (109,9 cm)	60" (152,4 cm)
depth	31" (78,7 cm)	35" (88,9 cm)
Weight	459 lbs (208,1 kg)	613 lbs (278,0 kg)
Electrical	3 Phase, 208-230 VAC, 60Hz	
running amps	approximately 21A	
fuse size	30A maximum	
breaker type	HACR or regular	
Compressor	3.5 hp semi-hermetic	
Drive Motor	5.44 hp	
Air Flow	Air cooled units require 12" (30,5 cm) air space at back	
Plumbing Fittings	Water cooled units require 3/4" N.P.T. water and drain fittings.	
Cylinder Capacity	6 gallon (22,72 liters)	
Liquid Mix Per Batch	4-8 quarts	
Working Cycle	8-12 minutes	
Warranty	Two-year warranty on freezing cylinder, compressor, drive motor, gearbox, and agitator shaft. One-year warranty on remaining parts and labor.	

Continuous research leads to ongoing product improvements; therefore, these specifications are subject to change without notice.

Distributed by:



STOELTING

FOODSERVICE EQUIPMENT

502 Highway 67 • Kiel, WI 53042-1600

920-894-2293 • 800-558-5807

Fax: 920-894-7029

E-mail: foodservice@stoelting.com

www.stoeltingfoodservice.com

ISO 9001:2000 Registered

Certified, Listed and/or Recognized by:

